

INSTALLATION AND USE OF PVC AND ALU PRODUCTS



Introduction

ROKO EuroWindows is based in Broomall, Pennsylvania and guarantees manufacture of the highest quality goods. Long service life and functionality of products depend on their proper installation, regular maintenance (at least once a year) and proper use as designed. Therefore, we recommend a thorough study of the instructions provided in the user's manual. Any deviation from the indication provided therein should be agreed with the manufacturer in writing.

1. Safety Precautions

Before using PVC and ALU products, read carefully the following instructions!

It is not allowed to:

- burden the casement with an extra weight
- leave windows and doors open wide or in a tilt position at unfavorable weather conditions (when wind or rain)
- leave any objects between the casement and the window frame
- leave any items in the roller shutters operation area (in the light between the guides)
- use products contrary to their designation or instructions
- use products which are incomplete or defective
- leave any objects with temperature much above ambient lying or standing close to PVC and ALU products, such as candles, irons, heaters, etc.

Failure to follow any of the above instructions may result in damage to products or be a hazard to health and life!

2. Storage and Transport

The products made of PVC and ALU should be transported in an upright position on a specially designed stand of a stable structure with the use of safety belts and appropriate spacers protecting against mechanical damage.

Storage should be on racks located on stable ground. The products should be protected against the weather factors (solar radiation, wind, precipitation, etc.), mechanical damage and pollution caused by sand, dust or other pollutants.

Some products are provided with a security system used for transport, which is located between the casement and the frame and removed after the installing (while opening the casement).

Most products are covered with a protective tape that must be removed immediately after the installing, but no later than three months after the date of purchase. Before deleting the tape, make sure it remains intact, thereafter check the product carefully to make sure there are no signs of damage.

3. Installation Instructions

Windows and doors function properly on the condition they are properly mounted by qualified assemblers!

3.1. General Rules for Installing Windows and Doors.

Make sure that the windows and doors are set exactly in vertical and horizontal position with respect to finished and properly prepared brickwork, ensure the wall is free from defects and irregularities. The window should be appropriately smaller than the opening in the brickwork, the discrepancy depends on the technical specifications of the window structure, on its color and type of mounting (including the sealing material). The general rule says that the opening should be 0.5 inch larger on each side than the complete window structure including spacing board.

3.2. Positioning in the Brickwork

Ensure the proper depth of mounting of the window or door in the wall, and so, in a single-layer brickwork the window or door should be positioned in the middle of the wall (Fig. 1), a double-layer brickwork requires closes pushing towards outer edge of the wall and up against the insulating layer, whilst the insulation should overlap the frame about 3 cm. (Fig. 2). In the three-layer brickwork, the window or door should be mounted in the plane of the insulating layer (Fig. 3), aligned with the inner layer of the brickwork!

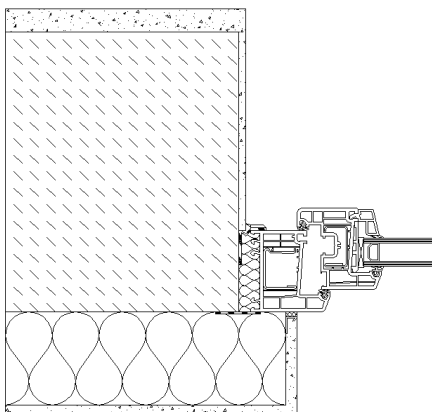

Fig. 1

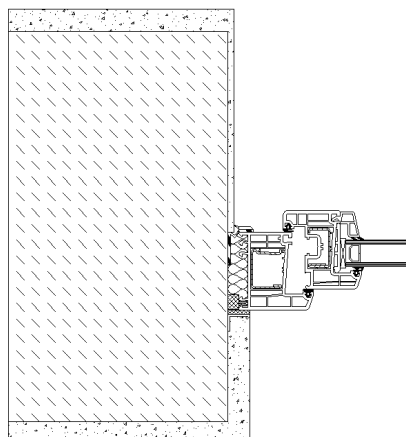

Fig. 2

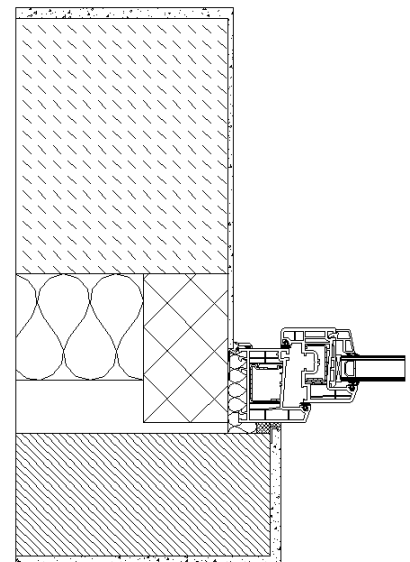
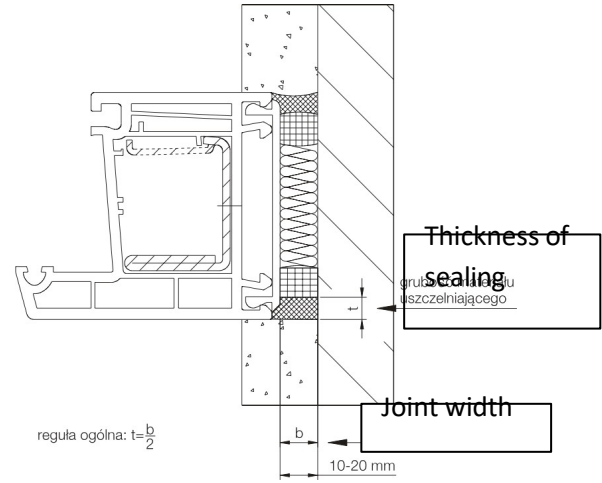

Fig. 3

3.3. Sealants and Joints

At temperatures below 40 degrees F pay attention to the specific properties of the materials used at installation. After fitting the casements to the frame, adjust the furniture. Gaps formed between the window or door and the brickwork, or between the profiles and the brickwork, must be sealed in accordance with the guidelines of ITB. There is a range of materials to seal the gaps between the frame and the wall, comprising commonly used assembly foams, mineral wool, polyethylene rollers, silicone and windproof foils as well as steam-tight foils or other materials approved for use by the ITB.



3.4. Casement Mounting and Dismantling

In order to be able to handle the window or door with ease during the mounting, remove the casement and mount the frame first.

Casement Dismantling

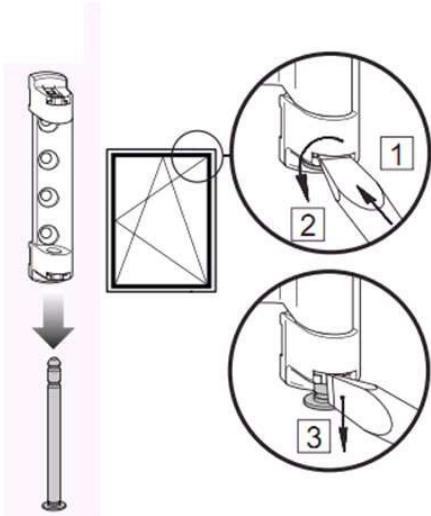

Casement Mounting

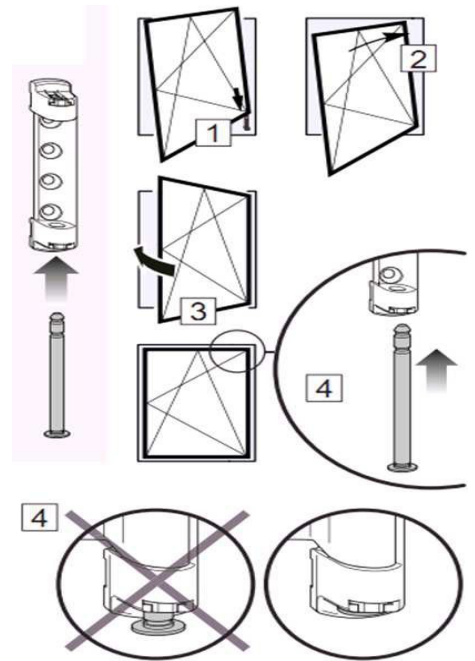

Note!

While inserting or removing the friction hinge pin, leave the casement closed!
With a use of a screwdriver (flat head) tighten up the hinge pin latch in the marked spot (1), then rotating the screwdriver (3) unlock the hinge pin and remove it, then separate the friction (spreader) from the hinge.

3.5. Fastening

Fastening should be performed in such a way that all predicted types of loads are transferred through the connectors to the building structure while maintaining the window fully functional. Relate to DIN 1055. The Frame should be installed around the perimeter as shown below.

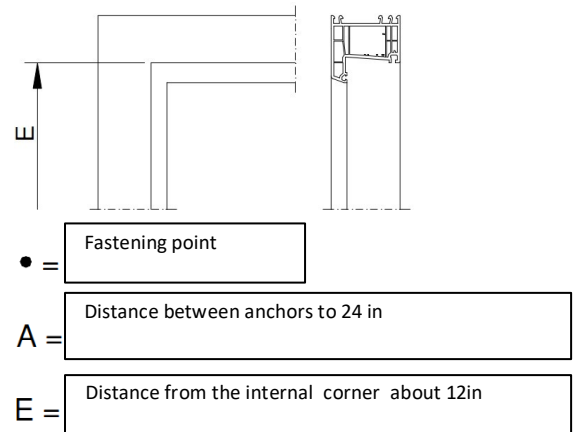
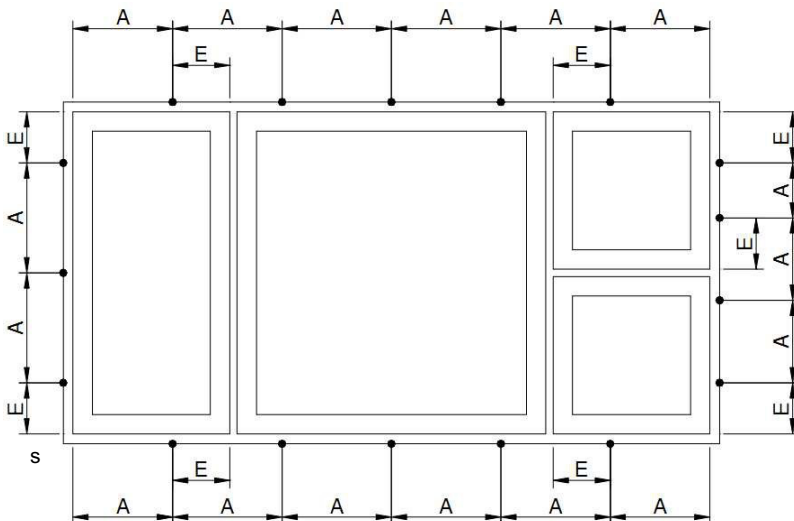

While choosing of a fixing agent consider the type of connection to the wall, working loads, and the construction situation. It is recommended to use wall anchors instead of drilling holes while fixing the upper and lower sections of the frame.

Use specifically designed for that purpose :

- expansion bolts made of galvanized steel equipped with insulating pads. The bolts are inserted into pre-drilled holes in the frame and tightened up. At least two bolts should hold each profile. The depth of fixture should be determined by the type of woodframe, ensuring they are at least 40mm deep.
- window frame fixing anchors of galvanized steel, fixed in the grooves of the frame profiles and bolted to the wall with anchors. Such an assembly eliminates drilling holes in the window and door frames and does not require the glazing to be removed before mounting the framing into the brickwork. Fastening with anchors also compensates for the thermal expansion of the profiles in the structure. The distance between anchors, and between the anchor and the window corner should be the same as the distance between expansion bolts.
- other fasteners permitted for securing PVC and Aluminum windows and doors.

For optimal transfer of forces acting in the plane of the window it is required to apply fixing pads. Ensure that the stresses are eliminated while settling the pads, neither let the sealant surface be disrupted. Fixing pads should be made of enduring and resistant material that guarantees that they are fixed in the joint permanently.

Distribution of Fixing Pads

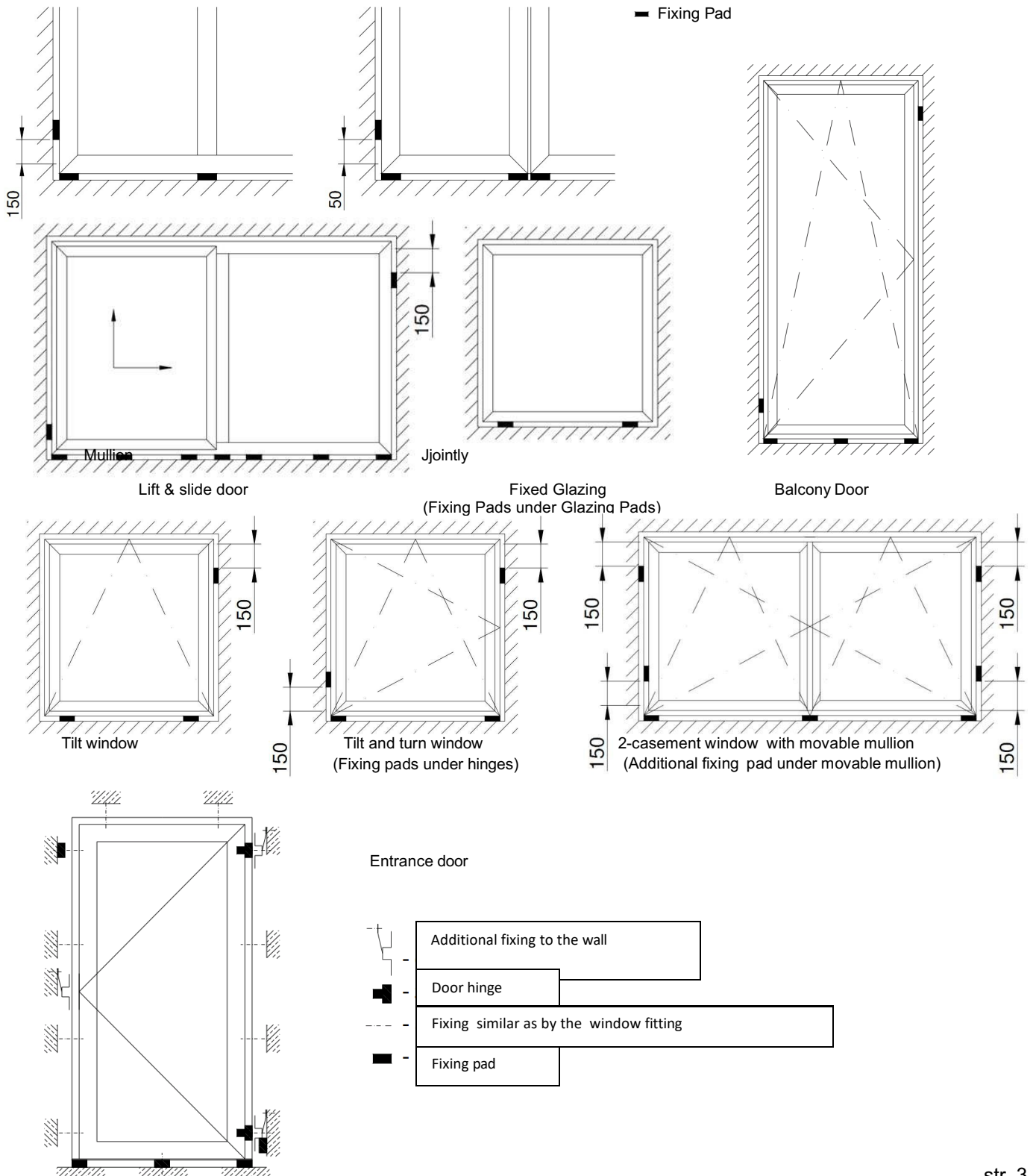

3.6. Connecting Systems

It is essential to connect systems permanently by means of specially designed bolts, while the link requires fixing with a sealant. The expansion joint is a special case of connection which should be fixed in such a way to allow the structure to work properly and at the same time remain stable.

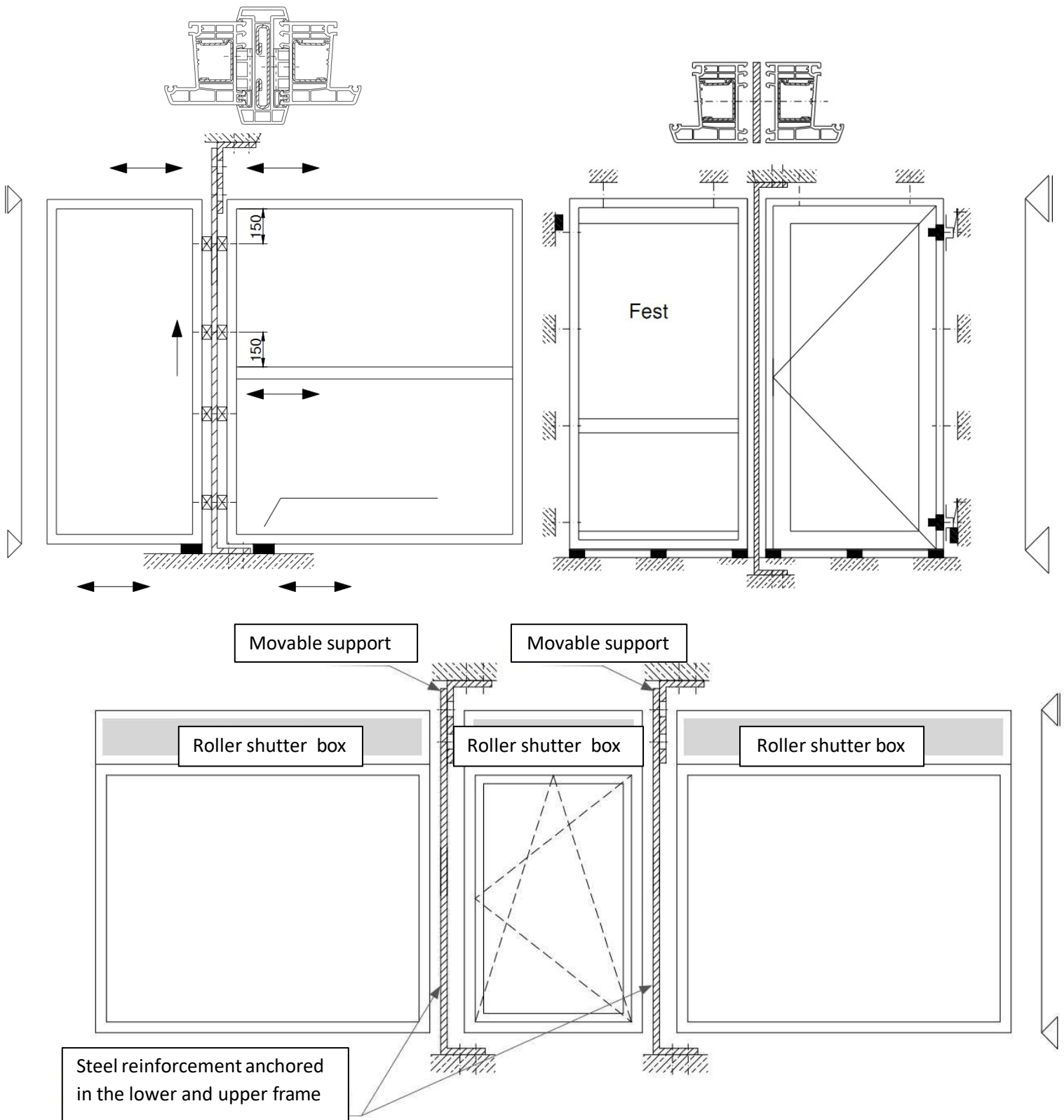

3.7. Mounting and Operating Roller Shutters

In case of windows equipped with build-on roller shutters, the shutter box has to be fastened to the lintel by means of securing anchors, spaced at the distance of 28 inch each.

To avoid distortions which might obscure functioning of the shutters during masonry, set the spacer between the box and the roller shutter curtain (see figure below).

Particular attention should be paid to the type of polyethylene foams being used, recommended are low expansion foams, important is also the mode of their application, make sure not to apply too much as this may cause swelling or damage the shutter and in consequence disrupt its functioning. Never limit the possibility of opening the inspection flap through any kind of work, neither masonry nor plastering or sealing, that would cut off an access to the inside of the shutter box.

Motor power supply cable must be fed through the PCV pipe, allowing the subsequent disassembly of the engine together with the power cord without damage to finishing works.

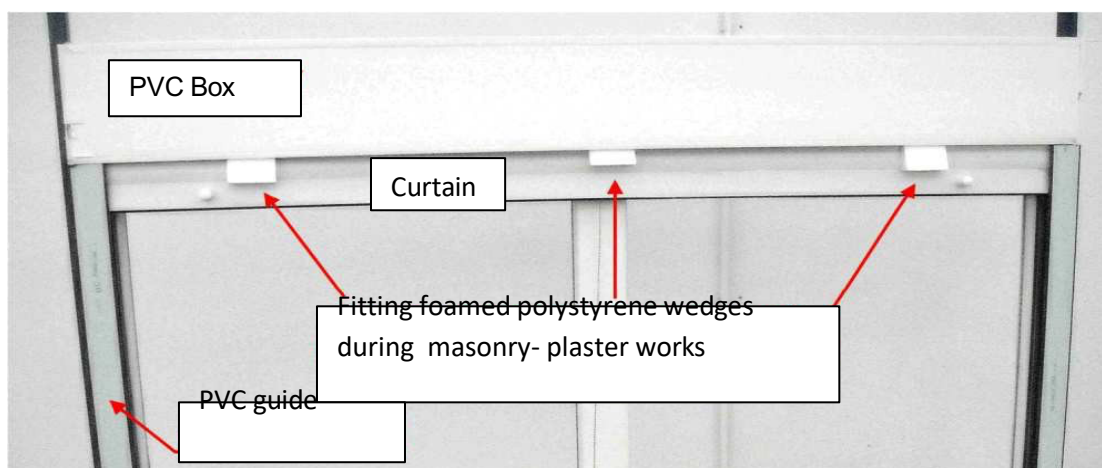

Tape drive

Raising roller shutters: grip the tape and pull it down, the relieved part of the tape that has been wound up by the coiler and the shutter will rise. Repeat the pulling several times until the roller shutter curtain has been stopped by the limiters of the lower curtain profile. This operation should be carried out slowly and smoothly in order to avoid "hitting" of the limiters against the box.

Lowering roller shutters: grip the tape just above the coiler and pull it towards you at an angle of approximately 20 degrees to the plane of the window to release the lock retractor. Then, still holding the tape, move it carefully towards the window in order to make the falling curtain cause the retractor draw the belt up. Repeat this several times until the shutter has been completely closed. Carry the operation out slowly to avoid the curtain lower profile "hitting" against any surface, e.g., the window sill.

Motor drive

Roller shutters with electric drive are lowered or raised by button switches or remote controls. Each drive is equipped with end stops, which will automatically stop the shutter in the upper or bottom positions as has been previously adjusted. The adjustment bears tolerance factor, therefore it is possible that the two neighbouring curtains do not stop level in the upper position.

Note !!!

In the winter season, there's a danger that the curtain may get frozen or icy. It is absolutely forbidden to use the roller shutter in this condition!

Before the use, if possible, gently crush the ice, or wait until it melts.

Two or more electric motors should not be plugged into one switch without the use of the control units serving this purpose (not applicable to radio controlled drives).

3.8 Mounting Accessories

Step cover is to be installed

according to the diagram by tightening of the attached screws into the openings of the cover and securing it with silicone.

The patent insert has to be inserted into the lock hole and positioned with the screw passing through the face of the lock.

Check the locking mechanism first, then install the protective covers of the lock, and fit the handles in such a way that the screws are placed inside the protected room.

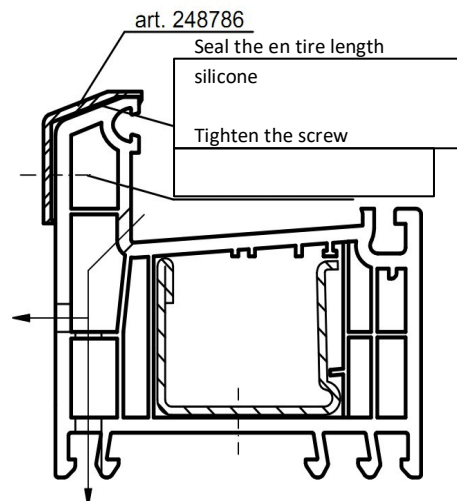

4. Final Use Instructions

4.1. General Rules

Tilt-and-turn furniture enables opening and tilting of the windows and patio doors by means of a handle, which can be set in the following positions:

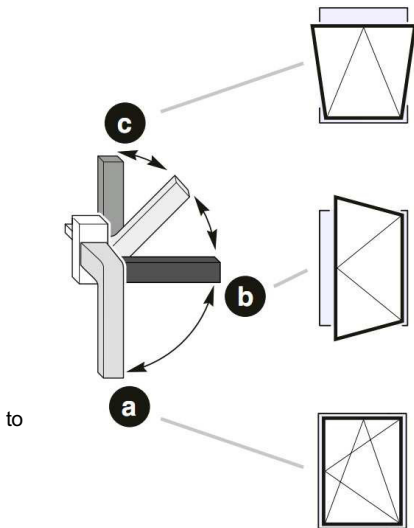

- a. Closed
- b. Open
- c. Tilted

The maximum tilt angle of the window depends on the window dimensions and the type of furniture/fittings.

Additional furniture, as MSL OS mechanism, can reduce the degree of the casement tilt. Instead of one, we can get a number of casement positions simply by turning the handle clockwise over the next "step". While changing the positions from "tilt" to "open", the casement must be aligned with the frame.

Turn and slide door, handle position :

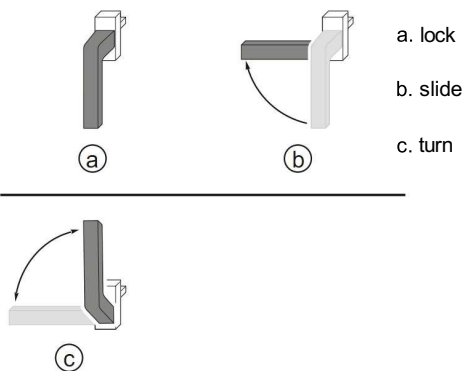

Turn and slide door with a handle control, handle position:

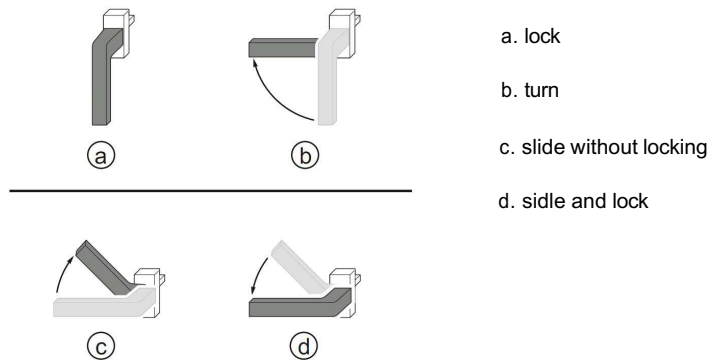

Overhead - slide door handle position:

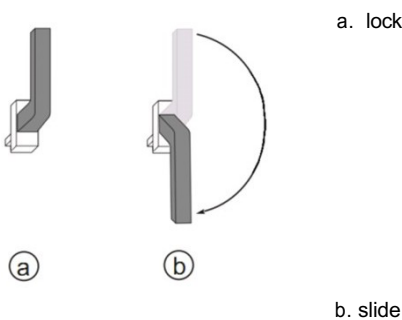

Note !

All operations should be strictly performed with the use of a handle.

Entrance Door

Closing of the entrance door prevents the door leaf from being opened by draft or pressure, while opening needs only straightforward pressing of the handle. In standard bolts, there is a latch responsible for closing of the door, then through turning of the lock cylinder the door becomes secured. The device functions in such a way that turning of the key releases a rigid lock bolt and launches additional securing

mechanism, while unlocking requires rotating of the cylinder in the reversed direction. Some doors which are equipped with an automatic door bolt which locks the door automatically after it has been closed but it is finally secured after turning of the lock cylinder.

Note! A double door bolt equipped with an extra lock should be secured first from the bottom lock. Reverse the order when opening.

4.2. Furniture Adjustment

Balcony Window and Door Adjustment

Simple adjustment of furniture leads to improvement of their performance and integrity.

Frame hinge/ Casement hinge

Height adjustment (+/- 3 mm) and side adjustment of the casement (+/- 2 mm)

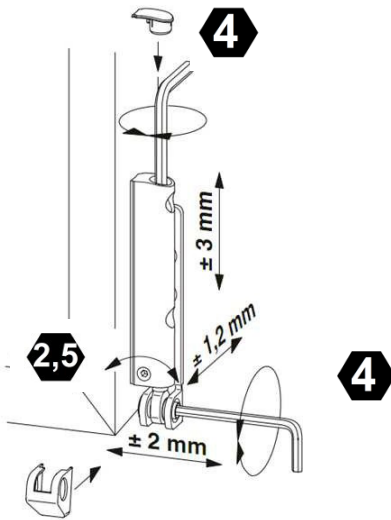

Octagonal cap

Clamp adjustment of the casement to the frame by turning of the octagonal cap (+/- 0,8)

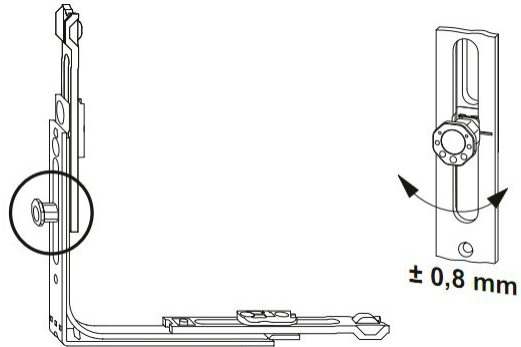

Friction hinge-Rectangular window

Side adjustment on the friction hinge (- 2 mm of the hinge, + 3 mm to the hinge)

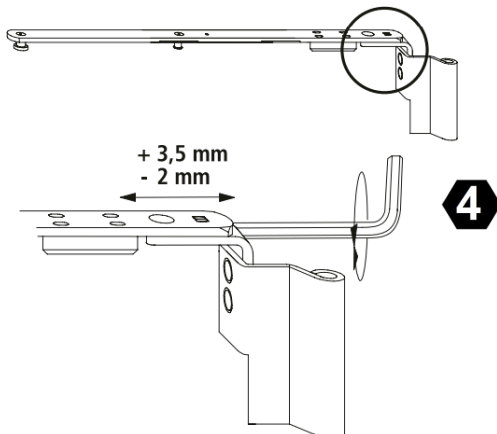

Friction hinge- Arch window

Side adjustment on the friction hinge

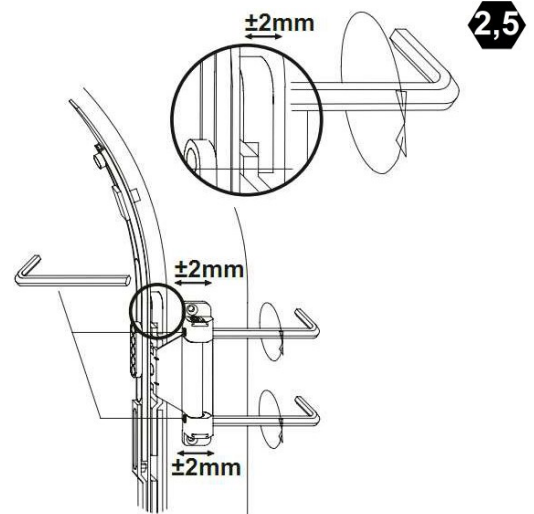

Casement clamp force with the latch

Clamp force control by proper adjustment of the circular cam

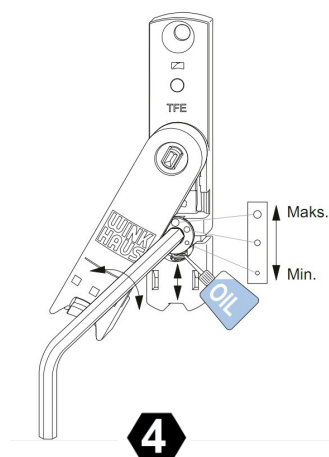

Frame part of item DFE/ TFE

Casement height control (+/- 3mm) by adapter DFE/ TFE. By each adjustment of the furniture check correct setting for the item at DFE/TFE

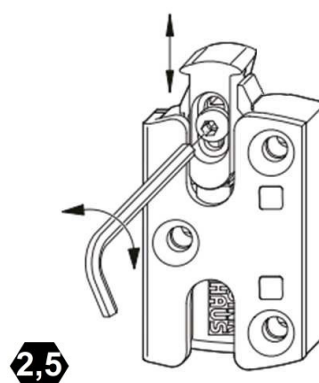

4.3. Air Circulation

PVC and ALU windows and doors are highly air-tight. Therefore, these products should be installed only in constructions equipped with either mechanical ventilation or a suitable air supply unit. It is very important to ventilate rooms properly and regularly by leaving all windows and doors open wide for 5 to 10 minutes in the morning and then 2 or 3 times for 2 to 5 minutes during the day. Note! Heating must be turned off.

5. Maintenance

The products require regular maintenance to keep them function faultlessly and ensure their long life-span for many years in a row.

It is recommended to carry out the following maintenance work once a year:

- check the working components for cooperation and furniture for proper functioning, all working parts and furniture should be lubricated with oil designed for that purpose,
- implement cleaners that do not violate anti-corrosion coating of furniture,
- check gaskets and preserve them with proper conservation agents,
- check the drainage holes of the frame, clear obstructions as necessary.

6. Cleaning

PVC & Aluminium Profiles

Protective tape located on the profiles should be removed immediately after the installation, no later than three months after the date of purchase. If the profile surfaces get polluted during the construction works, pollution should be gently removed through washing with water and mild detergent. Pollutants like dust or rain can be easily removed, in this case use soft cloth and apply cleaner that is available on the market and designed for this purpose.

Glass Panes

The best way to care about window panes is to use clean and warm water and soft cloth designed for cleaning. It is permitted to use generally available glass cleaners unless functional coating has been applied on the surface of the window pane.

Roller Shutters

Roller shutters should be cleaned in the same way as PVC profiles. Make sure the guide runners are clear of all obstructions and the inside brushes remain in good condition.

Note!

Never use:

- aggressive or solvent-based cleaners and polishes,
- nitro solvents, ketone, ester, aromatic hydrocarbons, chlorinated derivatives of hydrocarbons,
- abrasive agents such as lotions, powders, steel wool, abrasive coated sponge,
- other items that may scratch or damage surfaces, such as a spatula,
- fluid-based alkaline compounds, bleach, polishes, abrasives, or other solutions that may damage the oxide coatings (very important in the case of anodized or painted products).

7. TERMS OF WARRANTY

- I. ROKO Windows offers warranty under the following terms:
 1. Period of 5 years of guarantee for windows and doors - both PVC and Aluminium ones.

Warranty covers:

 - shape-durability of profile,
 - tightness of panes,
 - function of fittings,
 - adjustment of fittings -only if the products were acquired by the buyer and installed by our company and if there was a necessity to adjust the fittings within 3 months from the installation date.
 2. Period of 2 years for the other products comprising additional window equipment f.ex.outside roller shutters, put on roller shutter, control and electric drives, automatic control etc.
- II. Warranty is valid in the country in which the products were delivered and concerning only damages of products described in this agreement. The producer is obligated to consider the validity of the notification within 14 days from date of receipt. If the complaint is justified the producer obliges to repair the defect as soon as possible considering the time both needed for recognizing the reasons for the faults and ordering materials needed for repair the complaint product.
- III. If the complaint is unjustified the Producer is entitled to charge the reclamer the transport costs, costs of work (according to current rate).
- IV. Warranty does not cover:
 1. damage caused by improper:
 - installation by the customer or assembly group not authorized by producer.
 - use, maintenance,
 2. overt defects like: scratches, cracks, mechanical damage, etc.

The buyer is obliged to check the quantity and quality at the time of receipt of goods. Any divergences should be reported to the driver /warehouse attendant / assembly group and described in a report or WZ document under penalty of claims.
 3. damage caused by random events such as natural disasters
 4. damage caused by chemicals
 5. damages caused by out of adjustment fittings - fittings adjustment is on buyer's own initiative (according to manual).
 6. acceptable defects of glass, of which the visual assessment is made according to standards PN-EN ISO 12543-6, PN-EN 1096-1.
 7. cracks in glass caused by external factors and phenomenon of interference , anisotropy, deviations of colours and ringing window bars.
 8. PVC- door installed in public buildings.
- V. The document entitled to warranty service is the invoice.